

iSONIC WAVE XYZ automation module – the central building block for automation in ultrasonic welding systems

iSONIC WAVE XYZ is the new automation module from SONOTRONIC for performing servo-controlled ultrasonic welding. By simply moving the individual axes by hand, welding spots can be saved and fine-tuned in the program. Time-consuming offline integrations are replaced by simple teaching. An inexpensive and simple alternative to 6-axis industrial robots: light, highly dynamic and fast!

Due to the weight-reduced design as well as the connection of belt drives, driven by means of servo drives, a highly dynamic movement is achieved and thus a fast and exact positioning is guaranteed. The drives of the iSONIC WAVE XYZ gantry are directly integrated in the Siemens CPU via the S7 technology option package. Thus, the complete system can be programmed via the Siemens TIA portal. This ensures fast commissioning and fault diagnosis.

Optionally, a pneumatic axis can also be adapted to the Z-axis in order to perform welding pneumatically. In this combination, the gantry only takes over the positioning of the pneumatic axis.

Advantages

- Fast machining of vertical welding and joining tasks
- In-house manufacturing
- Stroke in X and Z direction individually adjustable
- Inexpensive alternative to 6-axis industrial robots
- Complete welding system from one source
- Fast commissioning and fault diagnosis



Infos online

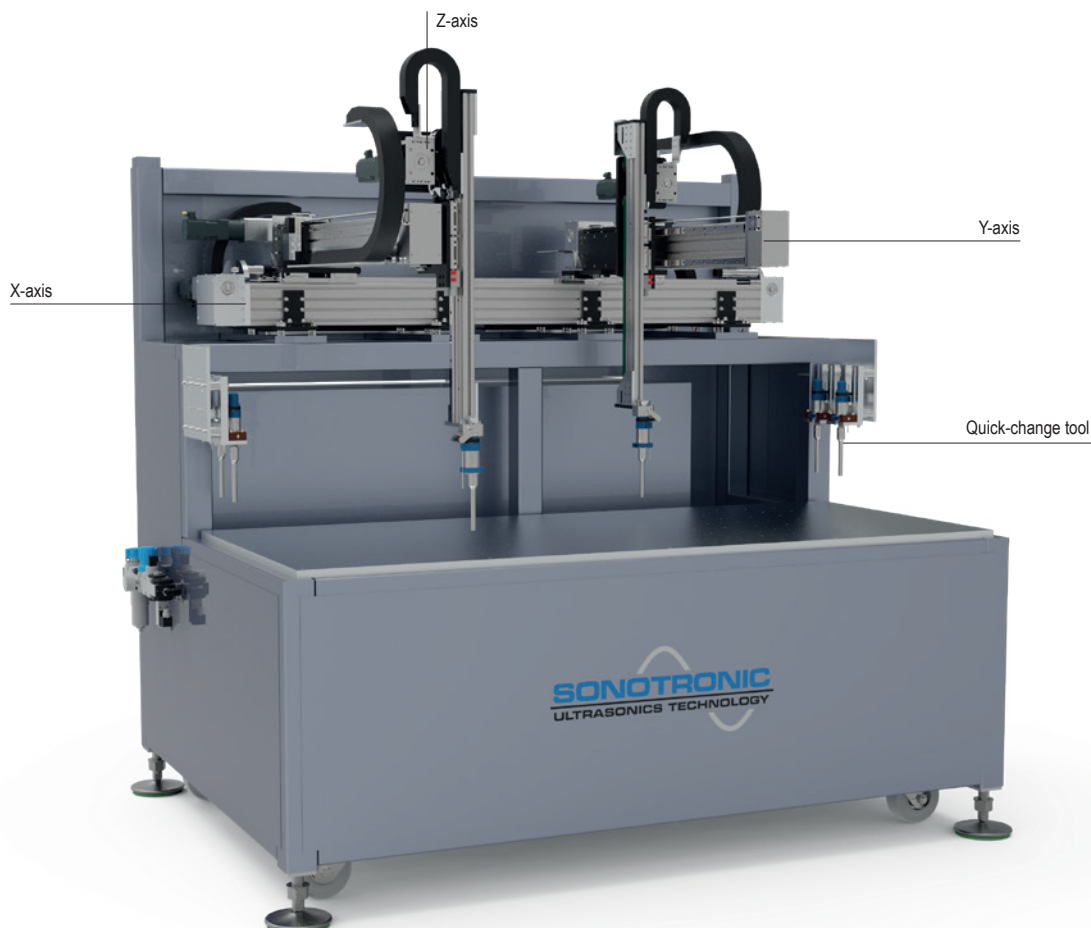

100 % SONOTRONIC – 100 % flexible

Efficient production processes

iSONIC WAVE XYZ, which is based on a Cartesian gantry, can be used both in the iSONIC FLEX and as a separate machine for vertical welding and joining tasks. Adapted to increasingly tight installation spaces, the iSONIC WAVE XYZ gantry is available as an individual solution, modular in length in the X and Z directions as required. The module can be integrated into the machine as a three-axis or six-axis system.

Quick-tool change

With the iSONIC WAVE XYZ, different part variants can be quickly and efficiently integrated into the production process by simply changing the coordinates. In order to cope with the high number of variants, both the workpiece carriers and the oscillating units can be changed easily. In terms of safety, the gantry has advantages over industrial robots, since the machining area is limited by the individual axes and thus the basic dimensions of the system are much smaller.

Features

- Focuses on user-friendliness
- Simple operation via handheld control unit (Mobile Panel)
- Quick and easy parameter determination of the XYZ position of the machining point through manual positioning
- Coordinate transfer of the machining point by setter
- No specialized personnel for robots necessary
- Different welding modes selectable (absolute, relative with scanning machining point via force, etc.)
- iSONIC WAVE XYZ axis control integrated in the Siemens control system

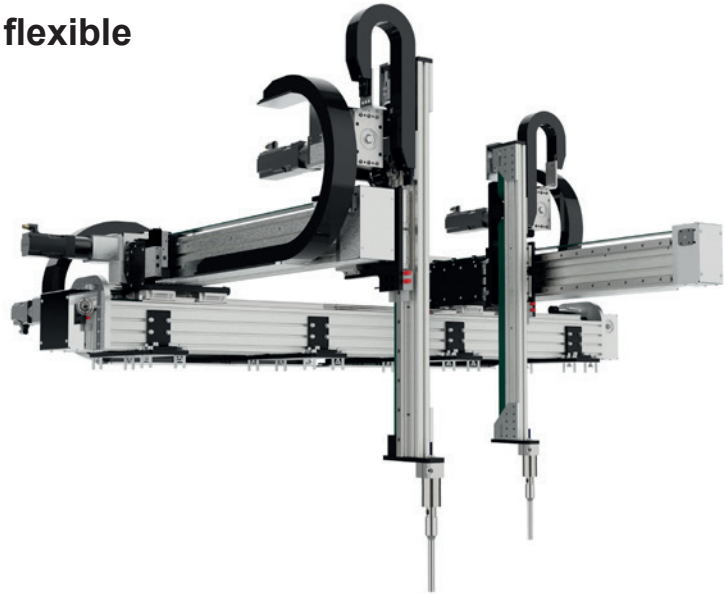

Technical data

Stroke X-axis adjustable [mm]	1000 (sample value)
Stroke Y-axis [mm]	600
Stroke Z-axis adjustable [mm]	300 (sample value)
Maximum welding force in Z-direction [N]	400
Execution	3-axis or 6-axis gantry
Technology	NC (servo drive)
Maximum speed [mm/s]	850



iSONIC WAVE XYZ
integration into production lines

